



Skovbrugsmaskiner – Træflishuggere – Sikkerhed

Forestry machinery – Wood chippers – Safety

COPYRIGHT ' Danish Standards. NOT FOR COMMERCIAL USE OR REPRODUCTION

DANSK STANDARD
Danish Standards Association

Kollegievej 6
DK-2920 Charlottenlund
Tel: +45 39 96 61 01
Fax: +45 39 96 61 02
dansk.standard@ds.dk
www.ds.dk

DS/EN 13525

København

DS projekt: 40415

ICS: 65.060.80

Første del af denne publikations betegnelse er:

DS/EN, hvilket betyder, at det er en europæisk standard, der har status som dansk standard.

Denne publikations overensstemmelse er:

IDT med: EN 13525:2005.

DS-publikationen er på engelsk.

DS-publikationstyper

DANSK STANDARD udgiver forskellige publikationstyper.

Typen på denne publikation fremgår af forsiden.

Der kan være tale om:

Dansk standard

- standard, der er udarbejdet på nationalt niveau, eller som er baseret på et andet lands nationale standard eller
- standard, der er udarbejdet på internationalt og/eller europæisk niveau, og som har fået status som dansk standard

DS-information

- publikation, der er udarbejdet på nationalt niveau, og som ikke har opnået status som standard, eller
- publikation, der er udarbejdet på internationalt og/eller europæisk niveau, og som ikke har fået status som standard, fx en teknisk rapport, eller
- europæisk præstandard

DS-håndbog

- samling af standarder, eventuelt suppleret med informativt materiale

DS-hæfte

- publikation med informativt materiale

Til disse publikationstyper kan endvidere udgives

- tillæg og rettelsesblade

DS-publikationsform

Publikationstyperne udgives i forskellig form som henholdsvis

- fuldtekstpublikation (publikationen er trykt i sin helhed)
- godkendelsesblad (publikationen leveres i kopi med et trykt DS-omslag)
- elektronisk (publikationen leveres på et elektronisk medie)

DS-betegnelse

Alle DS-publikationers betegnelse begynder med DS efterfulgt af et eller flere præfikser og et nr. fx **DS 383**, **DS/EN 5414** osv. Hvis der efter nr. er angivet at **A** eller **Cor**, betyder det, enten at det er et **tillæg** eller et **rettelsesblad** til hovedstandard, eller at det er indført i hovedstandard.

DS-betegnelse angives på forsiden.

Overensstemmelse med anden publikation:

Overensstemmelse kan enten være IDT, EQV, NEQ eller MOD

- **IDT:** Når publikationen er identisk med en given publikation.
- **EQV:** Når publikationen teknisk er i overensstemmelse med en given publikation, men præsentationen er ændret.
- **NEQ:** Når publikationen teknisk eller præsentationsmæssigt ikke er i overensstemmelse med en given standard, men udarbejdet på baggrund af denne.
- **MOD:** Når publikationen er modificeret i forhold til en given publikation.

EUROPEAN STANDARD

EN 13525

NORME EUROPÉENNE

EUROPÄISCHE NORM

January 2005

ICS 65.060.80

English version

Forestry machinery - Wood chippers - Safety

Machines forestières - Déchiqueteuses - Sécurité

Forstmaschinen - Buschholzhacker - Sicherheit

This European Standard was approved by CEN on 8 December 2004.

CEN members are bound to comply with the CEN/CENELEC Internal Regulations which stipulate the conditions for giving this European Standard the status of a national standard without any alteration. Up-to-date lists and bibliographical references concerning such national standards may be obtained on application to the Central Secretariat or to any CEN member.

This European Standard exists in three official versions (English, French, German). A version in any other language made by translation under the responsibility of a CEN member into its own language and notified to the Central Secretariat has the same status as the official versions.

CEN members are the national standards bodies of Austria, Belgium, Cyprus, Czech Republic, Denmark, Estonia, Finland, France, Germany, Greece, Hungary, Iceland, Ireland, Italy, Latvia, Lithuania, Luxembourg, Malta, Netherlands, Norway, Poland, Portugal, Slovakia, Slovenia, Spain, Sweden, Switzerland and United Kingdom.



EUROPEAN COMMITTEE FOR STANDARDIZATION
COMITÉ EUROPÉEN DE NORMALISATION
EUROPÄISCHES KOMITEE FÜR NORMUNG

Management Centre: rue de Stassart, 36 B-1050 Brussels

Contents

	Page
Foreword.....	3
0 Introduction.....	4
1 Scope.....	5
2 Normative references.....	5
3 Terms and definitions.....	7
4 Safety requirements and/or measures.....	8
4.1 General.....	8
4.2 Operator controls.....	9
4.2.1 General.....	9
4.2.2 Starting the machine.....	9
4.2.3 Stopping the machine.....	9
4.2.4 Infeed stop control.....	9
4.2.5 Safety and reliability of control systems.....	14
4.3 Protection against mechanical hazards.....	14
4.3.1 Stability.....	14
4.3.2 Risk of break-up during operation.....	14
4.3.3 Hazards related to infeed components and chipping components.....	15
4.3.4 Risks due to ejected objects.....	17
4.3.5 Protection against access to moving power transmission parts.....	17
4.4 Protection against non-mechanical hazards.....	18
4.4.1 Noise.....	18
4.4.2 Hydraulic components.....	19
4.4.3 Hot surfaces.....	19
4.4.4 Electrical hazards.....	19
4.5 Preparation for transport and maintenance.....	19
5 Verification of the safety requirements and/or measures.....	21
5.1 General.....	21
5.2 Stability.....	21
5.3 Chipping components risk of break-up.....	22
5.4 Hot surfaces.....	22
5.4.1 Temperature measuring equipment.....	22
5.4.2 Test method.....	22
5.4.3 Test acceptance.....	23
5.5 Verification of requirements on noise – Measurement of noise emission.....	23
6 Information for use.....	23
6.1 Instruction handbook.....	23
6.2 Marking.....	24
6.3 Warnings.....	25
Annex A (normative) List of significant hazards.....	26
Annex B (normative) Noise test code - Engineering method (grade 2).....	30
Annex ZA (informative) Relationship between this European Standard and the Essential Requirements of EU Directive 98/37/EC, amended by Directive 98/79/EC.....	33
Bibliography.....	34

Foreword

This document (EN 13525:2005) has been prepared by Technical Committee CEN/TC 144 "Tractors and machinery for agriculture and forestry", the secretariat of which is held by AFNOR.

This European Standard shall be given the status of a national standard, either by publication of an identical text or by endorsement, at the latest by July 2005, and conflicting national standards shall be withdrawn at the latest by July 2005.

This document has been prepared under a mandate given to CEN by the European Commission and the European Free Trade Association, and supports essential requirements of EU Directive(s).

For relationship with EU Directive(s), see informative Annex ZA, which is an integral part of this document.

According to the CEN/CENELEC Internal Regulations, the national standards organizations of the following countries are bound to implement this European Standard: Austria, Belgium, Cyprus, Czech Republic, Denmark, Estonia, Finland, France, Germany, Greece, Hungary, Iceland, Ireland, Italy, Latvia, Lithuania, Luxembourg, Malta, Netherlands, Norway, Poland, Portugal, Slovakia, Slovenia, Spain, Sweden, Switzerland and United Kingdom.

0 Introduction

This document is a type C standard as stated in EN ISO 12100-1.

The machinery concerned and the extent to which hazards, hazardous situations and events are covered are indicated in the scope of this document.

When provisions of this type C standard are different from those, which are stated in type A or B standards, the provisions of this type C standard take precedence over the provisions of the other standards, for machines that have been designed and built according to the provisions of this type C standard.

1 Scope

This document specifies safety requirements and their verification for design and construction of transportable, i.e. self-propelled, mounted, semi-mounted and trailed, wood chippers used in forestry, agriculture, horticulture and landscaping.

This document applies to chippers, used when stationary, which are manually loaded with wood through a horizontal or near horizontal infeed chute at the end of which mechanical infeed components (or chipping components acting as mechanical infeed components) draw the wood into the machine. The included wood chippers may be powered either by an external power source such as a tractor power take-off, hydraulics, etc or by an integral power source such as an internal combustion engine or an electric motor.

This document does not cover:

- requirements relating to national road regulations arising from transport between work sites;
- hazards arising from any self-propelled function;
- hazards arising from the transmission of power from an external power source – e.g. power take-off drive shafts;
- any machines where the infeed chute is fitted with an extension table;
- hazards arising from the engine pull starting of an integral power source;
- hazards arising from mechanical loading;
- vertical infeed chute chippers;
- electromagnetic aspects of the chippers;
- shredders/chippers to be covered by EN 13683.

This document deals with all significant hazards, hazardous situations and events relevant to wood chippers, when they are used as intended and under the conditions foreseen by the manufacturer (see Annex A).

In addition, it specifies the type of information to be provided by the manufacturer on the safe use of these machines.

It is not applicable to environmental hazards (except noise).

This document is not applicable to wood chippers which are manufactured before the date of publication of this document by CEN.

2 Normative references

The following referenced documents are indispensable for the application of this document. For dated references, only the edition cited applies. For undated references, the latest edition of the referenced document (including any amendments) applies.

EN 294:1992, *Safety of machinery – Safety distance to prevent danger zones being reached by the upper limbs*

EN 563:1994, *Safety of machinery – Temperatures of touchable surfaces – Ergonomics data to establish temperature limit values for hot surfaces*

EN 13525:2005 (E)

EN 811:1996, *Safety of machinery – Safety distances to prevent danger zones being reached by the lower limbs*

EN 953:1997, *Safety of machinery – Guards – General requirements for the design and construction of fixed and movable guards*

EN 954-1:1996, *Safety of machinery – Safety-related parts of control systems – Part 1: General principles for design*

EN 982:1996, *Safety of machinery – Safety requirements for fluid power systems and their components – Hydraulics*

EN 1175-2:1998, *Safety of industrial trucks – Electrical requirements – Part 2: General requirements of internal combustion engine powered trucks*

EN 10025-2:2004, *Hot rolled products of structural steels - Part 2: Technical delivery conditions for non-alloy structural steels*

EN 60204-1:1997, *Safety of machinery – Electrical equipment of machines – Part 1: General requirements (IEC 60204-1:1997)*

EN 60529:1991, *Degrees of protection provided by enclosures (IP Code) (IEC 60529:1989)*

EN 60947-5-1:2004, *Low-voltage switchgear and controlgear – Part 5-1: Control circuit devices and switching elements – Electromechanical control circuit devices (IEC 60947-5-1:2003)*

EN ISO 3744:1995, *Acoustics – Determination of sound power levels of noise sources using sound pressure - Engineering method in an essentially free field over a reflecting plane (ISO 3744:1994)*

EN ISO 4871:1996, *Acoustics – Declaration and verification of noise emission values of machinery and equipment (ISO 4871:1996)*

EN ISO 9614-1:1995, *Acoustics – Determination of sound power levels of noise sources using sound intensity – Part 1: Measurements at discrete points (ISO 9614-1:1993)*

EN ISO 9614-2:1996, *Acoustics - Determination of sound power levels of noise sources using sound intensity - Part 2: Measurement by scanning (ISO 9614-2:1996)*

EN ISO 11201:1995, *Acoustics – Noise emitted by machinery and equipment – Measurement of emission sound pressure levels at a work station and at other specified positions – Engineering method in an essentially free field over a reflecting plane (ISO 11201:1995)*

EN ISO 11204:1995, *Acoustics – Noise emitted by machinery and equipment – Measurement of emission sound pressure levels at a work station and at other specified positions – Method requiring environmental corrections (ISO 11204:1995)*

EN ISO 11688-1:1998, *Acoustics — Recommended practice for the design of low-noise machinery and equipment — Part 1: Planning (ISO/TR 11688-1:1995)*

EN ISO 12100-1:2003, *Safety of machinery – Basic concepts, general principles for design – Part 1: Basic terminology, methodology (ISO 12100-1:2003)*

EN ISO 12100-2:2003, *Safety of machinery – Basic concepts, general principles for design – Part 2: Technical principles (ISO 12100-2:2003)*

ISO 4413:1998, *Hydraulic fluid power – General rules relating to systems*

ISO 11684:1995, *Tractors, machinery for agriculture and forestry, powered lawn and garden equipment – Safety signs and hazard pictorials – General principles*

IEC 60245-1:2003, *Rubber insulated cables – Rated voltages up to and including 450/750 V – Part 1: General requirements*

3 Terms and definitions

For the purposes of this document, the terms and definitions given in EN ISO 12100-1:2003 and the following apply.

3.1

wood chipper

machine designed to reduce wood into chips

3.2

chipping components

rotating disc or drum or similar device with cutting tools or screw arrangement that performs the chipping operation and may perform also the infeed operation

3.3

infeed components

rollers and/or conveyors which feed wood into the chipping components

3.4

loading

method of presenting wood to the machine

3.4.1

horizontal loading

method where the wood is presented to the machine from its side in a horizontal direction

3.4.2

manual loading

method where the wood is presented to the machine is done manually by the operator

3.5

infeed chute

device through which wood is fed and guided to the chipping components and which may also provide the required safety distances

3.6

integrated feed conveyor

belt or similar conveyor, either in front of the infeed chute, or integral to the infeed chute which presents the wood to the infeed chute or to the infeed components

3.7

discharge chute

device through which the chipped material is guided away from the chipping components and which may also provide the required safety distances

3.8

run down time

time elapsed from the actuation of the stop control device until the chipping and/or infeed components come to a complete stop

3.9

reference plane

vertical imaginary plane (a) normal to the feed direction, at a point nearest to the operator (b) during the action of infeeding, where the distance between the infeed components is 25 mm or where the separation of the

infeed components is at its minimum if this is greater than 25 mm or where the infeed is achieved by the chipping components alone, the point nearest the operator where the chipping components are accessible

3.10 type A machines

machines where, on level ground and with the infeed chute in its designated working position, the outermost lower edge of the infeed chute is 600 mm or more from the ground, see Figure 2

3.11 type B machines

machines where, on level ground and with the infeed chute in its designated working position, the outermost lower edge of the infeed chute is less than 600 mm from the ground, see Figure 3

3.12 tool tip circle

path described by the outermost point of the cutting tools when rotating around their axis

Dimensions in millimetres

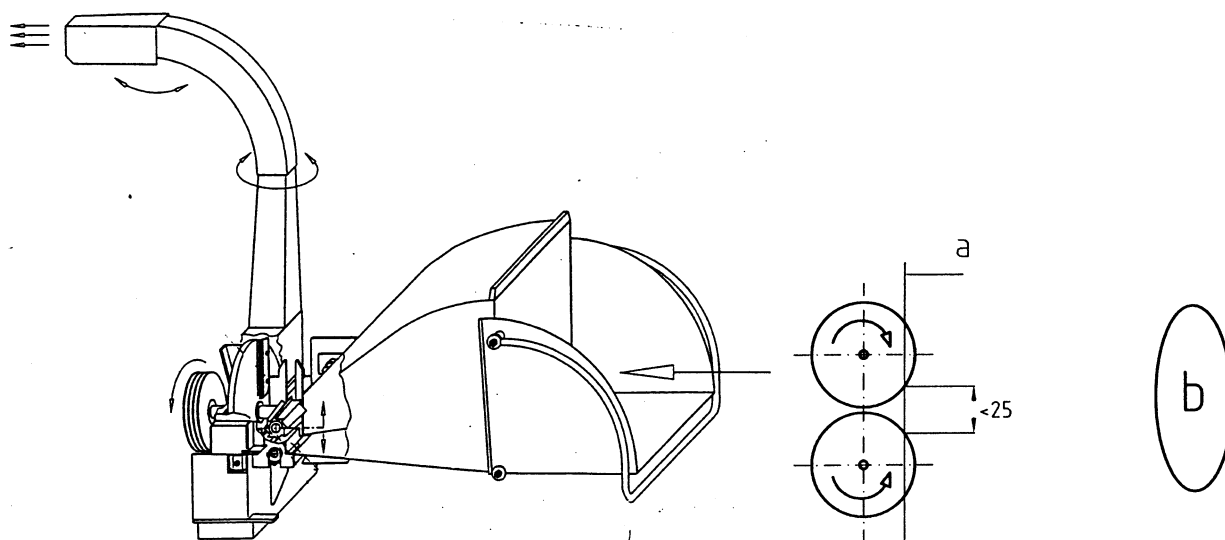

- Key**
- a Reference plane
 - b Operator

NOTE This example is a functional representation of a wood chipper and does not illustrate the safety measures required by this document.

Figure 1 – Example of wood chipper and reference plane

4 Safety requirements and/or measures

4.1 General

Machines shall comply with the safety requirements and/or protective measures of this clause. In addition, the machine shall be designed according to the principles of EN ISO 12100 for hazards relevant but not significant, which are not dealt with by this document (e.g. sharp edges).

Unless otherwise specified in this document all opening and safety distances shall comply with Tables 1, 3, 4 and 6 of EN 294:1992 and other aspects shall comply with the relevant parts of EN ISO 12100.

4.2 Operator controls

4.2.1 General

All machines shall have separate controls for starting/stopping the chipping components and for starting/stopping the infeed action meeting the requirements given below in 4.2.2, 4.2.3, 4.2.4. The safety and reliability of control system shall meet the requirements given in 4.2.5. Controls for stopping the chipping components shall also stop the infeed action.

4.2.2 Starting the machine

4.2.2.1 Where the machine is powered by an external power source, e.g. a tractor power take-off or a hydraulic system, the tractor power-take-off start control or hydraulic system control is regarded as the operator's control for starting the chipping components, infeed components and integral conveyors (where fitted).

4.2.2.2 Where the machine is powered by an integral power source, e.g. an internal combustion engine or an electric motor, the engine or motor start is regarded as the operator's control for starting the chipping components, infeed components and integral conveyors (where fitted).

4.2.2.3 Where an electric starter is used to start the integral power source, unauthorised activation of the starter shall be avoided by using one or more of the following methods:

- a key operated ignition or starting switch;
- a lockable cover for the ignition or starting switch;
- a security ignition or starting lock;
- a lockable battery disconnection switch.

4.2.3 Stopping the machine

4.2.3.1 Where the machine is powered by an external power source, e.g. tractor power take-off or hydraulic system, the external power source stopping controls such as the tractors engine stop control, the tractor power take-off control or hydraulic system control are regarded as the operator's control for stopping the machine.

4.2.3.2 Where the machine is powered by an integral power source, e.g. an internal combustion engine or electric motor, the engine or motor stop is regarded as the operator's control for stopping the machine.

4.2.3.3 Where integral power source is an internal combustion engine, the engine stop control shall not require sustained manual pressure for its operation and when once actuated it shall not be possible to restart the engine unless the control has been reset.

4.2.4 Infeed stop control

4.2.4.1 General

All machines shall have an infeed stop control. The design, position and function of the infeed stop control shall allow the operator when in the designated operating position, if entangled in the wood being fed into the machine, to stop the infeed action. The operator shall be able to engage the infeed stop control, in the direction of infeed, by using parts of the body other than just the hands (e.g. shoulder, elbow, torso, hip, legs etc.). To achieve this, it shall meet the positional requirements given in 4.2.4.2 and functional requirements in 4.2.4.3.

Whilst these requirements shall be fulfilled, the design, position and function of the infeed stop control shall seek to minimise inadvertent activation (nuisance tripping) by wood and branches as they are fed into the machine; and opportunities for the operator to remove, disconnect, disable, defeat, or jam the control.

4.2.4.2 Positional requirements

4.2.4.2.1 The infeed stop control shall be located in accordance with either 4.2.4.2.2, see Figure 2 or 4.2.4.2.3, see Figure 3, as appropriate to the height of the outermost lower edge of the infeed chute. At the infeed chute vertical edges, the infeed stop control shall cover a minimum of $0,75 \times h$. At the relevant horizontal edge, top or bottom, the infeed stop control shall cover the entire width of the edge.

4.2.4.2.2 For type A machines, the infeed stop control shall be located at the sides and at the lower edge of the chute, see Figure 2.

Dimensions in millimetres

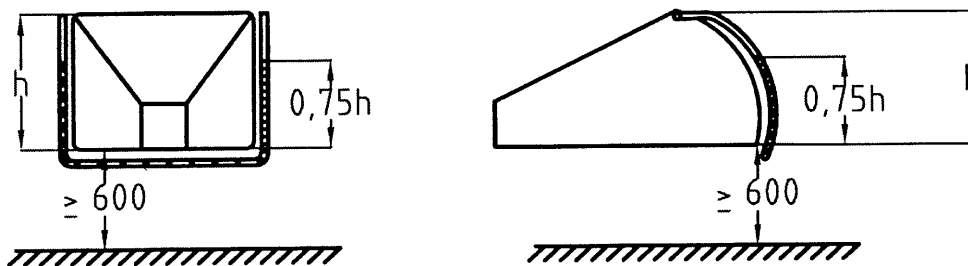

Key
 h Height of the chute side

Figure 2 – Location and coverage of the infeed stop control on type A machines

4.2.4.2.3 For type B machines, the infeed stop control shall be located at the sides and at the upper edge of the chute, see Figure 3.

Dimensions in millimetres

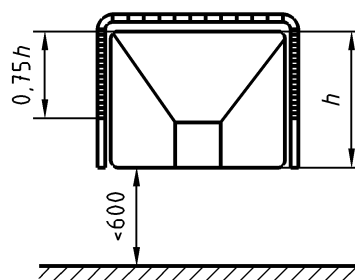

Key
 h Height of the chute side

Figure 3 – Location and coverage of the infeed stop control on type B machines

4.2.4.2.4 In either location, the position of the infeed stop control in relation to the outermost edge of the infeed chute shall be in accordance with the appropriate Figure 4 or Figure 5 such that:

- all positions of the infeed stop control that allow or cause infeed action are in front of the outermost edge of the infeed chute, i.e. zone B;

- from those positions, the infeed stop control shall be able to be moved to a position known as the 'emergency stop position', i.e. position C; and
- this emergency stop position is in the position closest to the outermost edge of infeed chute but sufficiently in front of that edge for the emergency stop position to be successfully engaged, i.e. the respective operation completed, by the operator in the manner described in 4.2.4.1 in the event of entanglement.

4.2.4.2.5 The positions/functions of the infeed stop control shall be clearly indicated on both sides of the infeed chute and also in the instruction handbook. The colour of the infeed stop control shall be preferably red or yellow. Where other colours are used, they shall be bright and in contrast to the background colour of the infeed chute.

4.2.4.2.6 In the case of machines with an integrated feed conveyor, the infeed stop control shall meet the requirements of 4.2.4.2.4. Instead of meeting the location requirements of 4.2.4.2.1 the infeed stop controls shall be provided at the sides and at the outer end of the conveyor. Any reverse action of the conveyor shall have a hold-to-run control located within reach of the operator but outside of reach to the danger zones and in a position providing good visibility of the conveyor and the infeed components.

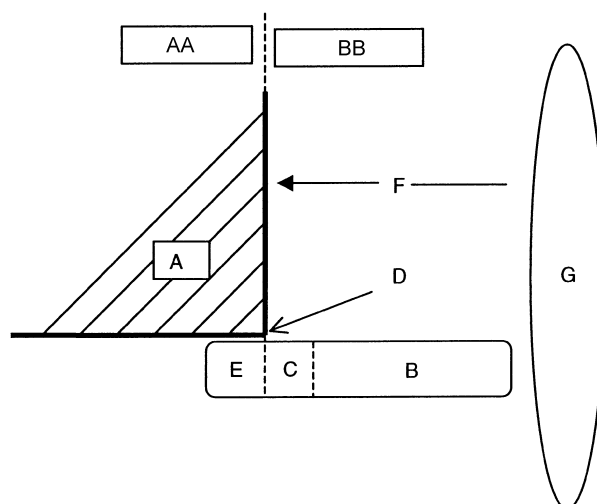

Key

- AA Behind the outermost edge of the infeed chute
- BB In front of the outermost edge of the infeed chute
- A Infeed chute
- B Zone for all positions of infeed stop control that allow or cause infeed or reverse action
- C Emergency stop position
- D Outermost lower edge of the infeed chute
- E Optional additional position for the infeed stop control where the only permitted function is reverse of a hold-to-run type
- F Direction of infeed
- G Operator's position

Figure 4 — Schematic representation of the relationship between the positions of the infeed stop control, the outermost lower edge of the infeed chute and the position of the operator when feeding type A machines

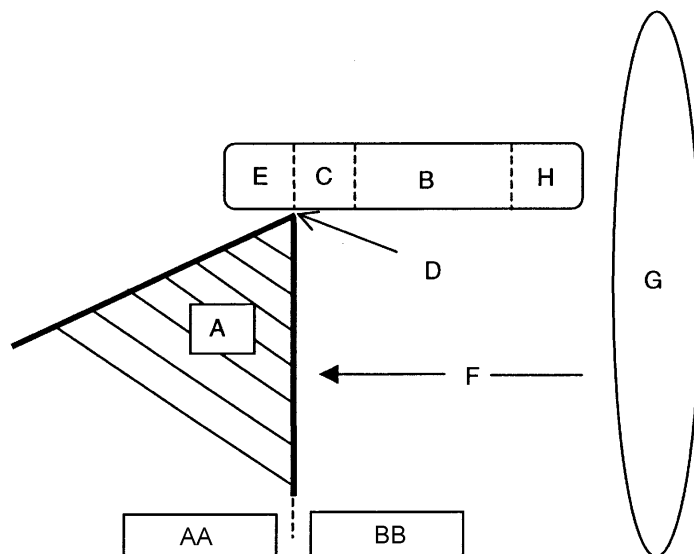

Key

- AA Behind the outermost edge of the infeed chute
- BB In front of the outermost edge of the infeed chute
- A Infeed chute
- B Zone for all positions of infeed stop control that allow or cause infeed or reverse action
- C Emergency stop position
- D Outermost upper edge of the infeed chute
- E Optional additional position for the infeed stop control where the only permitted function is reverse of a hold-to-run type
- F Direction of infeed
- G Operator's position
- H Position of the infeed stop control where the only permitted functions are stop or reverse

Figure 5 — Schematic representation of the relationship between the positions of the infeed stop control, the outermost upper edge of the infeed chute and the position of the operator when feeding type B machines

4.2.4.3 Functional requirements

4.2.4.3.1 All machines shall comply with 4.2.4.3.2 to 4.2.4.3.6 inclusive. Type B machines shall also meet the requirements of 4.2.4.3.7. Where the infeed stop control incorporates other functions for controlling the infeed components, they shall meet the appropriate requirements of 4.2.4.3.8 to 4.2.4.3.10.

4.2.4.3.2 Actuation of any part of the infeed stop control shall have the same functional result.

4.2.4.3.3 Movement of the infeed stop control from zone B to position C, as defined in 4.2.4.2.4, shall stop infeed action. Actuation to the emergency stop position shall have priority over any other controls used to operate the infeed components as defined in 4.2.4.3.6.

4.2.4.3.4 The force required to actuate the infeed stop control from zone B to position C (see Figures 4 and 5) shall not exceed 150 N on the horizontal part of the infeed stop control (including those provided on machines with an integrated feed conveyor) and 200 N on other parts along the length $0,75 \times h$ as specified in 4.2.4.2.1. The force required shall be measured in a horizontal direction $\pm 15^\circ$, or in the case of a pivoting infeed stop control, in the tangential direction of its movement.

4.2.4.3.5 On actuation of the infeed stop control to position C, the time taken for infeed action to stop shall be as short as practicable and in all instances less than the minimum time for wood to travel from the nearest position of the infeed stop control to the reference plane.

4.2.4.3.6 When actuated to position C, the operator shall not be able to restart infeed action by solely returning the infeed stop control to any position in zone B. The operator shall only be able to restart infeed action by deliberate actuation of a separate control provided for this purpose.

4.2.4.3.7 In addition to meeting the requirements of 4.2.4.3.2 to 4.2.4.3.6, for type B machines the infeed stop control shall stop or reverse infeed action when pulled to its outermost position against the direction of feed, i.e. to position H.

4.2.4.3.8 Where the infeed stop control incorporates a control position for reversing the infeed action, the operation of that function shall be hold-to-run if it is behind the outermost edge of the infeed chute, i.e. at position E, see Figure 4 or Figure 5 as appropriate. Position E shall be as close as possible to the outermost chute edge of the infeed chute.

4.2.4.3.9 For type A machines, in respect of the infeed direction from the operator to the outermost edge, all positions of the infeed stop control in zone B, which allow or cause infeed action, shall be before any position which stops infeed action.

4.2.4.3.10 For type A machines, where the infeed stop control provides other functions to control the infeed components, examples of permitted control patterns include:

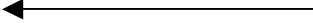
reference plane infeed direction operator

- optional reverse (hold-to-run), [chute edge], emergency stop function, infeed;
- optional reverse (hold-to-run), [chute edge], emergency stop function, reverse, infeed;
- optional reverse (hold-to-run), [chute edge], emergency stop function, infeed, reverse;
- optional reverse (hold-to-run), [chute edge], emergency stop function, reverse, stop, infeed.

4.2.4.3.11 For type B machines, where the infeed stop control provides other functions to control the infeed components (including the requirements of 4.2.4.3.7) examples of permitted control patterns include:

reference plane infeed direction operator

- optional reverse (hold-to-run), [chute edge], emergency stop function, infeed, stop;
- optional reverse (hold-to-run), [chute edge], emergency stop function, infeed, reverse;
- optional reverse (hold-to-run), [chute edge], emergency stop function, infeed, reverse, stop;
- optional reverse (hold-to-run), [chute edge], emergency stop function, reverse, infeed, stop;
- optional reverse (hold-to-run), [chute edge], emergency stop function, infeed, stop.

4.2.5 Safety and reliability of control systems

4.2.5.1 The safety related control systems shall comply with category 1 of EN 954-1:1996, 6.2.

4.2.5.2 The electrical components shall comply with:

- EN 60947-5-1:2004, Clause 3, for control switches with automatically opening contacts used as mechanically operated position switches for interlocking circuits and for relays used in control circuits;
- EN 60947-5-1 for electromechanical protection devices and engine starting motors used in main circuits;
- IEC 60245-1 for rubber-insulated leads.

4.3 Protection against mechanical hazards

4.3.1 Stability

4.3.1.1 Machines shall be stable when operated in accordance with their specified conditions of use (i.e. within the specified limitations of factors affecting stability such as angle of slope, ground conditions, size of material being chipped etc.). In particular:

- except for the main transport wheels, supporting devices (e.g. jockey wheels, stands, outriggers, etc.) shall have a bearing surface designed to limit the ground pressure to a maximum of 400 kPa;
- chippers which are self-standing during the chipping operation, shall be stable with the largest size of wood being fed in.

4.3.1.2 When stored according to the instruction handbook on a concrete surface, with an inclination of up to 8,5° in any direction, the machine shall be capable of resisting a force of 400 N applied in any direction without tilting. This requirement shall be met for all combinations of the following, when any or all:

- fuel, oil or other tanks are empty;
- fuel, oil or other tanks are full;
- chutes are in their transport or folded position(s);
- chutes are in their working position(s);
- guards are in their closed position;
- guards are in their open position.

4.3.2 Risk of break-up during operation

4.3.2.1 The chipping components and their attachments shall be designed to withstand twice the operating speed whilst unloaded. This requirement shall be verified according to 5.2.

4.3.2.2 The casing enclosing the chipping components shall prevent parts of the chipping components from being ejected through the casing by centrifugal force. If steel plate of grade S235JR according to EN 10025-2 is used as casing material, the total wall thickness in areas where chipping component parts may be thrown shall comply with the requirements of Table 1. Figures given in Table 1 are based on tool rotational frequency of 1 000 min⁻¹.

Table 1 – Total wall thickness for steel casing

Dimensions in millimetres	
Diameter of the chipping components tool tip circle d	Minimum steel thickness (S235JR)
$d \leq 600$	4
$600 < d \leq 800$	6
$800 < d \leq 1\,000$	8
$d > 1\,000$	10

In case the rotational speed exceeds $1\,000 \text{ min}^{-1}$ or other materials or designs such as screw-type chippers are used, the casing shall provide equivalent protection.

4.3.3 Hazards related to infeed components and chipping components

4.3.3.1 Machines with infeed components

4.3.3.1.1 For type A machines where the working position of the outermost lower edge of the infeed chute is equal to or more than $1\,000 \text{ mm}$ from the ground, the minimum horizontal distance from the chute outer edge to the reference plane shall be according to EN 294:1992, Table 2, see Figure 6.

Dimensions in millimetres

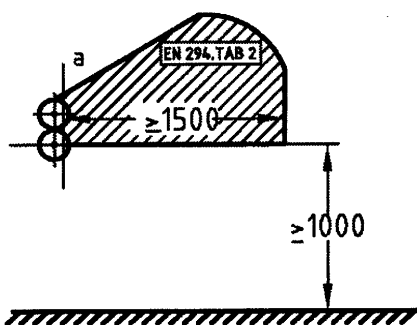

Key

a Reference plane

Figure 6 – Infeed chute length, high chute location

Machines with an infeed chute not more than 700 mm wide shall meet the dimensions given in Figure 7 whereby:

- the distance from the outermost lower edge of infeed chute to the reference plane shall be at least $1\,200 \text{ mm}$;
- the distance from the outermost upper edge of the infeed chute to where the floor of the chute meets the infeed components shall be at least $1\,000 \text{ mm}$;

the distance between the outermost lower and upper edges measured in parallel with the reference plane shall be not more than 400 mm. For infeed chutes designed as in Figure 7 it shall not be possible for the infeed chutes to be used in positions lower than 1 000 mm.

Dimensions in millimetres

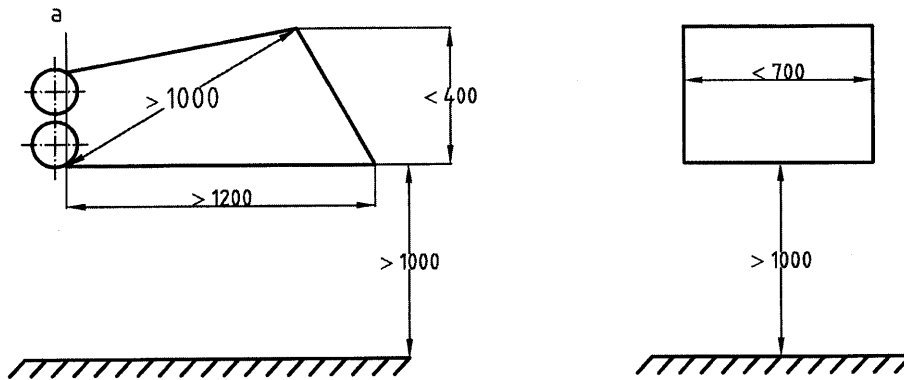

Key

a Reference plane

Figure 7 – Infeed chute length, high chute location, alternative design

4.3.3.1.2 For type A machines where the working position of the lower edge of the infeed chute is between 600 mm to 1 000 mm from the ground, the minimum horizontal distance shall be 1 500 mm from the reference plane to any part of the chute outer edges below 1 000 mm. Where the chute outer edges extend above 1 000 mm, EN 294:1992, Table 2 applies. See Figure 8.

Dimensions in millimetres

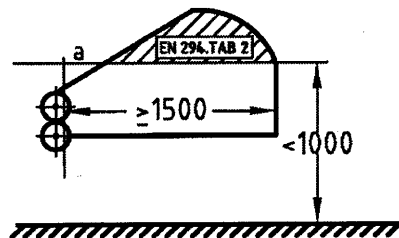

Key

a Reference plane

Figure 8 – Infeed chute length, low chute location

4.3.3.1.3 In machines where the working position of the lower edge of the infeed chute is less than 600 mm from the ground, type B machines, the minimum horizontal distance from the chute outer edge to the reference plane shall be 1 200 mm at the whole chute edge, see Figure 8. In addition the following requirements apply:

- the height from the centre line of the infeed control to the lower edge of the chute shall be not greater than 1 000 mm; and
- the bottom of the chute shall be sloping away from the infeed components towards the chute outer edge.

Dimensions in millimetres

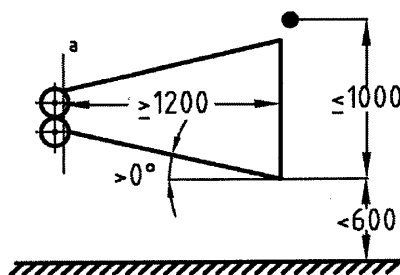
**Key**

a Reference plane

Figure 9 – Infeed chute length and control to chute lower edge height, type B machines**4.3.3.2 Guarding of chipping components**

For guarding the chipping components from directions other than the infeed chute the following applies.

The access to chipping components shall be prevented by use of either:

- a fixed guard where the time required to remove it is longer than the run-down time of the chipping components; or
- an interlocking guard with guard locking, in accordance with EN 953.

In case of a fixed guard, visual means, e.g. a dual-colour axle end under a transparent cover, shall be provided to indicate whether the chipping components are moving or not.

4.3.4 Risks due to ejected objects

4.3.4.1 The chipper shall not eject wood or chips from the infeed chute, which by virtue of their shape, size, velocity or direction, pose a risk to an operator or bystander.

NOTE Means of achieving this requirement will be considered at the next revision of this document.

4.3.4.2 Where a machine provides for reversing of the infeed components, the speed of wood, when reversed, shall not exceed 1,0 m/s if the control for engaging reverse function is positioned where the operator may be at risk of being struck by wood as it is reversed.

4.3.4.3 The discharge chute shall be designed to minimise the risk of ejected objects to workers. Means shall be provided to prevent discharge towards the infeed area of the chipper, e.g. by limiting the discharge chute movement.

4.3.5 Protection against access to moving power transmission parts

4.3.5.1 All moving parts of the power transmission system shall be designed, constructed, positioned or otherwise provided with guards or protective devices to prevent all risk of contact.

4.3.5.2 To ensure protection against hazards related to accessible moving power transmission parts, the machines shall be fitted with guards according to EN 953.

Moving power transmission parts not required to be accessed during use shall be fitted with fixed guards.

Moving power transmission parts required to be accessed during use for maintenance or machine adjustment shall be guarded as follows:

- if the moving parts can be brought to a stop immediately by either a fixed guard or an interlocked guard;
- if the moving parts cannot be brought to a stop immediately by either a fixed guard or an interlocked guard with guard locking.

The time taken for the removal of any fixed guard shall be longer than the run-down time of any of the moving parts which those guards are protecting against access. Fixed guards shall remain attached to the machine when opened for example by means of hinges and automatically lock in the closed position without the use of a tool.

4.3.5.3 Guards according to EN ISO 5674 and EN 12965 can also be used to protect drive shafts within the machinery.

4.3.5.4 Transmission of power from external power sources

On machines powered via a power take-off (PTO) drive shaft, the straight line overlap of the PTO drive shaft guard with the power input connection (PIC) guard shall be not less than 50 mm. This minimum overlap shall also apply to protection devices of wide-angle PTO drive shafts and when using clutches or other elements.

Suitable fixing points shall be provided for the restraining device used to prevent the rotation of the drive shaft guard.

The machine shall be supplied with a support for the PTO drive shaft when the machine is uncoupled, but this shall not be the device used to prevent the rotation of the PTO drive shaft guard.

The PIC guard shall be so constructed and attached to the machine that, in conjunction with the PTO drive shaft guard, it encloses the drive shaft on all sides up to the first fixed bearing housing of the machine, whilst allowing for fitting and articulation of the PTO drive shaft.

4.4 Protection against non-mechanical hazards

4.4.1 Noise

4.4.1.1 Noise reduction as a safety requirement

4.4.1.1.1 Noise reduction at source by design and by protective measures

The machine shall generate a noise level as low as practicable. The methodology for designing low-noise machinery described in EN ISO 11688-1 shall be used.

NOTE EN ISO 11688-2 gives useful information on noise generation mechanisms in machinery.

The main sources causing noise in wood chippers include e.g.:

- infeed mechanism;
- chipping components;
- chip discharge;
- power source.

The noise reduction measures by design include e.g.:

- selecting low noise components e.g. engine;
- selecting proper materials;

- selecting proper thickness and coating of surfaces;
- optimisation the knife mounting configuration;
- optimisation of the knife/feeding angle;
- selecting low noise exhaust system.

4.4.1.1.2 Noise reduction by information

If after taking all possible technical measures for reducing noise at the design stage a manufacturer considers that further protection of the operator is necessary, then the instruction handbook shall:

- recommend the use of low-noise operating modes, and/or limited time operation;
- give a warning of the noise level and recommend the use of ear protection.

4.4.2 Hydraulic components

Hydraulic systems shall be designed and constructed in accordance with ISO 4413.

Hydraulic lines and fittings shall meet the requirements of EN 982.

Pressurised hoses, lines and components shall be located or shielded so that in the event of rupture, the fluid cannot be discharged directly on to the operator.

4.4.3 Hot surfaces

A guard shall be provided to prevent accidental contact with any exposed engine exhaust components larger than 10 cm² which have a surface temperature greater than 80 °C at (20 ± 3) °C ambient temperature during normal starting and operation of the machine. This requirement shall be tested according to 5.2.

NOTE The temperature of 80 °C is to be reviewed at the next revision of this document taking into account any relevant values given in EN 563.

4.4.4 Electrical hazards

4.4.4.1 The electrical equipment of electrically driven machines shall comply with EN 60204-1.

4.4.4.2 Casing of the switch gear or the control gear equipment shall at least comply with IP 54, casing of motors shall comply at least with IP 44 according to EN 60529.

4.4.4.3 The electrical and related mechanical safety requirements for the design and construction of the electrical installation on machines with integral internal combustion engines shall meet the requirements of EN 1175-2.

4.5 Preparation for transport and maintenance

4.5.1 Folding or displacing the infeed or discharge chutes, e.g. for transport, shall only be possible when the chipping components and/or infeed components are stationary or if the following safety distances/openings are met during the folding/displacement of the chute and when the chute is in its folded/displaced position:

- the requirements set out in 4.3.3; or
- the values of EN 294:1992, Tables 3, 4 and 6; and

for infeed chutes on type B machines the values of EN 811:1996, Table 1.

Once the respective chute is in its folded or displaced position, it shall not be possible to start the chipping components and/or infeed components unless the safety distances/openings specified in this clause continue to be met.

4.5.2 The instruction handbook shall describe all the tools, work practices, safety/auxiliary devices, and personal protective equipment required when carrying out maintenance on the machine. It shall also indicate that, for maintenance and repair interventions and cleaning operations in danger zones, wood chippers shall be either uncoupled from their power source or, in case of machines with integral power sources, shall be prevented from unauthorised starting by use of the means provided by virtue of 4.2.2.3.

4.5.3 Operators unlocking or opening guards to clean and/or maintain stationary shipping components shall be alerted to any possible risks by suitable warning signs attached to the guard in a prominent position.

4.5.4 When maintaining the machine the stability requirements in 4.3.1 shall apply.

4.5.5 A locking device, e.g. a pin or hook, shall be provided to prevent inadvertent movement of chipping components whilst they are being maintained, adjusted. This requirement does not apply when the process of sharpening requires continuous rotation of the component. Requirements of 4.1 apply also during the tool sharpening process with use of an integrated tool sharpening device, if provided.

4.5.6 If the infeed or discharge chutes/conveyors have to be folded for transport or maintenance they shall have for the purpose two handles located at a distance of at least 300 mm from the nearest articulation point. These handles can be integral parts of the machine provided they are designed and positioned in accordance with good ergonomic principles and clearly identified. The force required to fold and to reassemble any such chute/conveyor shall not exceed 250 N when measured at the handle provided. Means shall be provided to lock the foldable parts in their folded position.

4.5.7 If it is necessary to climb onto the machine for the above folding operation or for any maintenance or adjustment purpose a proper means of boarding with foot supports (e.g. rungs or steps) and handholds shall be provided.

Such means of boarding shall comprise of steps in accordance with Figure 10 and as follows:

- the inclination α shall be between 80° and 90° from the horizontal. Each step shall have a slip-resistant surface, a lateral stop at each end and be so designed that accumulation of mud and snow is minimised in the normal conditions of work. The vertical and horizontal distance between successive steps shall be within a tolerance of ± 20 mm; or
- shall be designed as a ladder. The top side of each rung shall have a horizontal slip-resistant surface at least 30 mm from front to back. If rungs can be used as handholds then rectangular section rungs shall have corner radii ≥ 5 mm.

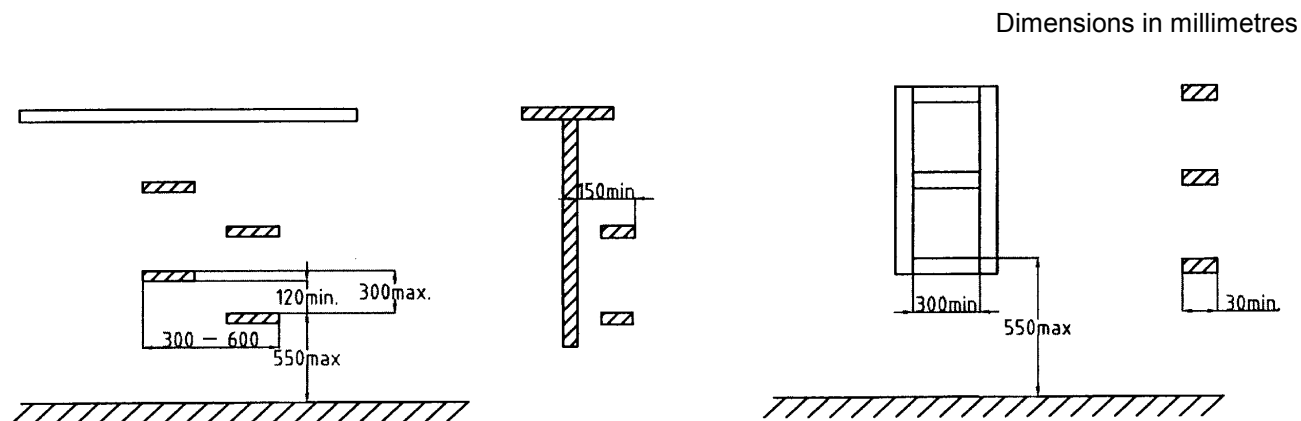

Figure 10 – Boarding means

4.5.8 Servicing or maintenance locations shall have slip-resistant surfaces and suitable handholds.

4.5.9 For machines with a PTO drive shaft above the coupling device, the means of access shall not be above the PTO drive shaft. By design PTO drive shafts and their guards shall not be considered as steps.

4.5.10 Outriggers or similar devices shall also be secured e.g. with pins or latches in their transport position. It shall be possible for the operator to verify visually from the driving position that the outriggers are in the transport position.

5 Verification of the safety requirements and/or measures

5.1 General

Dimensions, where given shall be verified by measurements. Controls shall be verified by a function test and positional measurements; guards by functional test. Test methods and acceptance criteria, where given shall be used and met.

5.2 Stability

5.2.1 The stability of the machine in use shall be verified by the following tests:

- a) with all supporting devices (e.g. jockey wheels, stands, outriggers, etc) deployed. The pressure under each supporting device (not the main transport wheels) shall be measured and not exceed the values stated in 4.3.1.1.
- b) with all supporting devices deployed, the machine shall not tilt when a branch of maximum diameter and of a length equal to the distance between the reference plane and the outermost lower edge of the infeed chute is placed on the floor of the infeed chute. The branch shall be otherwise unsupported.

5.2.2 The stability of the machine when stored shall be verified by the machine not tilting during the following tests.

- a) place the machine, prepared for storage in accordance with the instruction handbook, on a firm surface (e.g. wood, metal, concrete etc) with a slope of 8,5°;
 - i) with all tanks empty and with all guards and chutes in their closed position, apply a force of 400 N to the highest surface of the machine which is perpendicular to the slope; the force shall be applied in parallel with the slope and in a downslope direction;

- ii) remove the applied force, rotate the machine 45° about its central vertical axis and re-apply the force as described in i);
 - iii) repeat i) and ii) until the entire machine has completed a single revolution;
 - iv) repeat i), ii) and iii) with all guards and chutes open, moving the position of the applied force as necessary;
 - v) repeat i), ii) and iii) with all tanks full;
 - vi) repeat i), ii) and iii) with all tanks full and with all guards and chutes open, moving the position of the applied force as necessary.
- b) when prepared for storage in accordance with the instruction handbook, determine the furthest point (Point X) of the machine from any main transport wheel or supporting device. Place this point at the bottom of the 8,5° slope;
- i) with the tanks empty and with all guards and chutes closed, apply a force of 400 N perpendicular to the slope at Point X;
 - ii) repeat i) with all guards and chutes open, moving the position of the machine and the applied force as necessary if Point X changes;
 - iii) repeat i) with all tanks full;
 - iv) repeat i) with all tanks full and with all guards and chutes open, moving the position of the machine and the applied force as necessary if Point X changes.

5.3 Chipping components risk of break-up

The chipping components and their attachments risk of breaking up during operation shall be tested by running the chipping components unloaded for two minutes at twice the operating speed as indicated by the manufacturer. No deformation or cracks shall occur in the components after the test.

5.4 Hot surfaces

5.4.1 Temperature measuring equipment

The temperature measuring equipment shall have an accuracy of ± 4 °C.

5.4.2 Test method

The engine shall be operated at its maximum operating speed until the surface temperatures stabilise. The test shall be conducted in the shade. Temperatures shall be determined by correcting the observed temperature difference between the specified ambient and the test ambient temperature.

Identify the hot area(s) on the engine exhaust system.

When the distance between the identified hot area and the nearest control is in excess of 100 mm, cone A as shown in Figure 11 shall be used. For distances less than 100 mm between the identified hot area and the nearest control, cone B shall be used.

Dimensions in millimetres

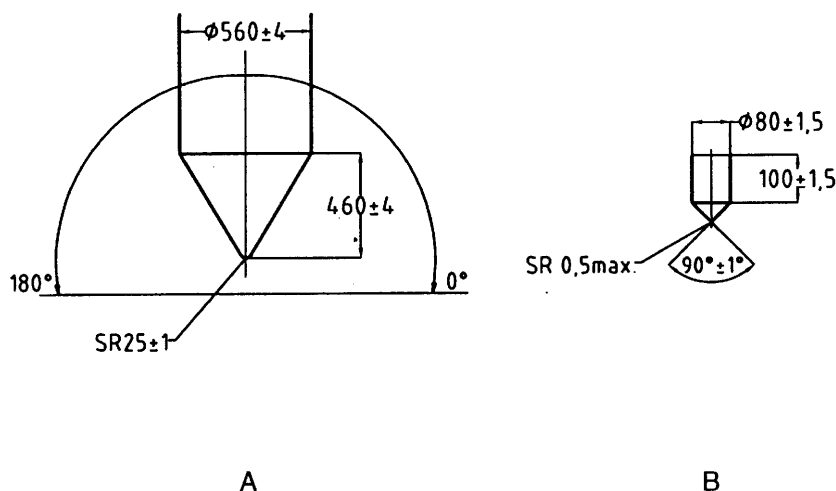
**Key**

SR Spherical radius

Figure 11 - Test cones

For cone A, with the axis of the cone anywhere between 0° and 180° to the horizontal and with the nose or point of the cone in a downward to horizontal direction, move the cone towards the hot surface. The cone shall not be moved in an upwards direction. When moving the cone, determine if contact is made with the hot surface area(s) with the cone tip or conical surface of the cone.

Cone B shall be moved in any direction.

5.4.3 Test acceptance

When tested in accordance with 4.4.3.3, using the test equipment given in 4.4.3.2 the tip or conical surface of cone A or B shall not make contact with the hot surface or the exhaust system as described in 4.4.3.1. No part of the exposed machine shall exceed the temperature values given in EN 563.

5.5 Verification of requirements on noise – Measurement of noise emission

For the determination of the sound power level and of the emission sound pressure level at the operator's position the measurement method given in Annex B shall be used.

6 Information for use**6.1 Instruction handbook**

Comprehensive instructions and information on all aspects of maintenance and the safe use of the machine shall be provided in the instruction handbook. It shall comply with Clause 6.5 of EN 12100-2:2003.

In particular the following points shall be emphasised:

- a) intended uses of the machine;
- b) commissioning the machine;

EN 13525:2005 (E)

- c) any relevant training requirements including the correct working practices to safely operate and maintain the machine;
- d) information regarding required personal protective equipment;
- e) precautions to be taken with moving parts of the working process;
- f) description and function of all controls and an explanation of the symbols and text used;
- g) purpose of the warning signs attached to the machine;
- h) warning to keep guards and shields in place when the machine is running;
- i) warning not to remove, jam, disable or otherwise impede the effectiveness of the infeed stop control;
- j) warning not to position the chute in higher or lower positions such that the effectiveness of the infeed stop control is compromised;
- k) warning to stay clear of the chip discharge area;
- l) warning not to use inside buildings;
- m) warning to lock the starting control in the 'off' position or disconnect the machine from the prime mover before maintenance or servicing;
- n) warning not to use a trailed or mounted chipper unattached from its power source;
- o) intervals for inspecting and/or replacing safety critical components and devices;
- p) general requirements for routine lubrication, maintenance and the use of special tools;
- q) safe methods for filling and draining tanks and reservoirs;
- r) information on correct methods of hitching/attaching, supporting, tying-down and lifting the machine, including the allowed loading on those points;
- s) hazards associated with batteries and electrical supply including need to use a portable residual current device (PRCD) unless provided in the electrical system;
- t) procedures to be followed when adjustments are to be made with the machine running;
- u) use of devices to keep machine elements (including chipping components, raised guards and covers, etc.) in a safe position during service and maintenance;
- v) information concerning the replacement of hydraulic hoses;
- w) values of noise emission measured and declared according to Annex B and recommendation to wear personal hearing protectors.

6.2 Marking

The marking shall comply with 6.4 of EN ISO 12100-2:2003.

All machines shall be marked legibly and indelibly with at least the following information:

- name and address of the manufacturer;
- year of construction;

- designation of series and type;
- serial number, if any;
- nominal rotational frequency and direction of rotation of the power input connection (marked by an arrow), when applicable;
- mass in kilograms;
- nominal power in kW, when applicable.

6.3 Warnings

Warnings on the machine shall be in accordance with 6.3 of EN 12100-2:2003 or ISO 11684. The purpose of the warnings shall be explained in the instruction handbook.

In particular the following warnings shall appear on all chippers respectively at the locations stated:

- risk of being pulled into the feed mechanism, on the inside and outside of the infeed chute;
- not to climb into the infeed chute, on the inside and outside of the infeed chute;
- to wear eye protection against the risk of ejected material, on the outside of the infeed chute;
- risk of cutting, on the access to infeed and/or chipping components;
- a list of 'do's' and 'don'ts', including necessary actions before operating the machine (e.g. reading the instruction manual before operation, proper sitting of the machine, checking the infeed chute is clear etc.), correct starting and stopping procedures and steps to make the machine safe for servicing, maintenance and/or storage etc. on the main control panel.

In addition, on machines externally powered through a power take-off (PTO) drive shaft the following warning shall appear:

- against exceeding the nominal rotational speed of the machine, on the power input connection (PIC) guard;
- disconnect the PTO drive shaft before servicing and maintenance, close to the PIC guard and on the control panel;
- attach the machine to the external power source before operation (e.g. secure to 3-point linkage of the tractor), close to the PIC guard and on the control panel;
- ensure chipper is on level surface before detaching from external power source (e.g. from the tractor 3-point linkage), on the side of chipper close to the linkage points.

Annex A (normative)

List of significant hazards

This clause contains, for defined danger zones, the significant hazards, hazardous situations and events, covered by this document, that have been identified by risk assessment as being significant for these types of machines and which require specific action by the designer or manufacturer to eliminate or to reduce the risk (see Table 1).

Table A.1 — List of significant hazards associated with wood chippers

N°	Hazard	Location or event	Reference of this document
1.1	Crushing hazard	Machine tilting, contact with unguarded infeed, chipping components, unguarded power transmission components, preparation for transport or maintenance, crushing between the wood and infeed chute	4.3.1, 4.3.3, 4.3.5, 4.5, 6.1
1.2	Shearing hazard	Contact with unguarded infeed or chipping components, unguarded power transmission components, preparation for transport or maintenance	4.3.3, 4.3.5, 4.5, 6.1
1.3	Cutting or severing hazard	Contact with unguarded infeed or chipping components, unguarded power transmission components, preparation for transport or maintenance	4.3.3, 4.3.5, 4.5, 6.1
1.4	Entanglement hazard	Improper location of infeed stop control, contact with unguarded infeed or chipping components, contact with the PTO drive shaft or other parts of power transmission	4.2.4, 4.3.3, 4.3.5, 4.5, 6.1
1.5	Drawing-in or trapping hazard	Contact with unguarded chipping or feeding components, contact with the PTO drive shaft or other parts of power transmission	4.3.3, 4.3.5, 6.1
			(continued)

Table A.1 — List of significant hazards associated with wood chippers (continued)

N°	Hazard	Location or event	Reference of this document
1.6	Impact hazard	Risk of break-up of the chipping components casing, wrong direction of the chip discharge, risk of objects ejecting from the chipping components	4.3.2, 4.3.4, 6.1
1.9	High pressure fluid injection or ejection hazard	Hazardous location or unguarded pressurised hoses	4.4.2
2.1	Contact of persons with live parts (direct contact)	Contact of fingers with unguarded electrical components	4.4.4
2.2	Contact of persons with parts which have become live under faulty conditions (indirect contact)	Contact with fingers with unguarded electrical components	4.4.4
2.3	Approach to live parts under high voltage	Contact with unguarded electrical components	4.4.4
2.5	Thermal radiation or other phenomena such as the projection of molten particles and chemical effects from short circuits, overloads, etc.	Hazardous location of cables	4.4.4
3.1	Burns, scalds and other injuries by a possible contact of persons with objects or materials with extreme high or low temperature, by flames or explosions and also by the radiation of heat sources	Contact with unguarded engine exhaust parts	4.4.3
4.1	Hearing loss (deafness), other physiological disorders (e.g. loss of balance, loss of awareness), accidents due to interference with auditory warning signals and speech communication	Hearing damage due to the working machine	4.4.1, 6.1
7.1	Hazards from contact with or inhalation of harmful fluids, gases, mists, fumes, and dusts	Leakage from or rupture of hydraulic lines or components, indoor use of internal engine powered chippers	4.4.2, 6.1
7.2	Fire or explosion hazard	Indoor use of internal engine powered chippers	6.1
7.3	Biological or microbiological (viral or bacterial) hazards	Improper direction of chip discharge	4.3.4
			(continued)

Table A.1 — List of significant hazards associated with wood chippers (continued)

N°	Hazard	Location or event	Reference of this document
8.1	Unhealthy postures or excessive efforts	Height of the infeed chute, mass of machine elements to be folded for transport or maintenance	4.5.5
8.2	Inadequate consideration of hand-arm or foot-leg anatomy	Infeed stop control improper location, inability to activate it	4.2.4
8.3	Neglected use of personal protective equipment	Damages from ejected objects, hearing damages	4.3.4, 4.4.1, 6.1
8.6	Human error, human behaviour	Infeed stop control improper functioning, trying to reach onto the infeed chute	4.2.4, 4.3.3
8.7	Inadequate design, location or identification of manual controls	Infeed stop control improper location, inability to activate it	4.2.4
10.1	Failure/disorder of the control system	Control system failures	4.2.5
10.2	Restoration of energy supply after an interruption	Unexpected starting of the machine	4.2.5
11	Impossibility of stopping the machine in the best possible conditions	Control system failure	4.2.3, 4.2.5
13	Failure of power supply	Unexpected starting of the machine	4.2.5
14	Failure of the control circuit	Wrong category of control system	4.2.5
15	Errors of fitting	Improper tightening of the chipping components	6.1
16	Break-up during operation	Chipping components casing breaking, improper chipping tools attachment, operating PTO-driven machines at too high speed	4.3.2, 6.1, 6.2
17	Falling or ejected objects or fluids	Objects ejecting from the chipping components, improper direction of the chip discharge, rupture of pressurised hoses, lack of eye protectors	4.3.2, 4.3.4, 4.4.2, 6.1
18	Loss of stability/overtipping of machinery	Improper location or size of supporting devices, operation of PTO-driven machines when uncoupled from the power source	4.3.1, 6.1
			(continued)

Table A.1 — List of significant hazards associated with wood chippers (concluded)

N°	Hazard	Location or event	Reference of this document
19	Slip, trip and fall of persons (relating to machinery)	Lack, improper location or size of boarding means	4.5.6
21.2	Exhaust gases/lack of oxygen at the work position	Indoor use of internal engine powered chippers	6.1
22.1	Inadequate location of manual controls	Improper location or operation of operator control	4.2
22.2	Inadequate design of manual controls and their mode of operation	Improper location or operation of operator controls	4.2
23	From handling of the machine (lack of stability)	Machine tilting, lack or improper location of supporting devices, operation of PTO-powered machines when uncoupled to the power source	4.3.1, 6.1
24.3	Hazards from coupling and towing	Operation of PTO-powered machines when uncoupled to the power source	6.1

Annex B (normative)

Noise test code - Engineering method (grade 2)

B.1 Scope

This noise test code specifies all the information necessary to carry out efficiently and under standardised conditions the determination, declaration and verification of the noise emission characteristics of wood chippers.

Noise emission characteristics include emission sound pressure levels at workstations and the sound power level. The determination of these quantities is necessary for:

- manufacturers to declare the noise emitted;
- comparing the noise emitted by machines in the family concerned;
- purposes of noise control at the source at the design stage.

The use of this noise test code ensures reproducibility of the determination of noise emission values within specified limits determined by the grade of accuracy of the basic noise measurement method used. Noise measurement methods allowed according to this annex are engineering methods (grade 2).

B.2 Emission sound pressure level determination

B.2.1 Emission sound pressure levels shall be measured in accordance with EN ISO 11201 or EN ISO 11204. EN ISO 11204 shall be used to engineering method Grade 2.

B.2.2

B.2.2.1 The following emission sound pressure levels shall be determined over the work cycle specified in B.6 at the operator's positions:

- 'A'-weighted time-averaged sound pressure level;
- 'C'-weighted peak emission sound pressure level, if required.

B.2.2.2 The operator shall be present during the emission sound pressure level determination. The microphone shall be head-mounted 20,0 cm \pm 2 cm from the median plane of the head on the louder side and in line with the eyes. Standing operators shall be 1,75 m \pm 0,05 m tall, including shoes.

B.2.2.3 The operator shall be positioned so that she/he is able to control the infeed action and as specified by the manufacturer in the operator's instruction handbook. The position shall be recorded.

B.3 A-weighted sound power level determination

B.3.1 The sound power level shall be determined by using one of the following documents. The preferred document for determining sound power is EN ISO 3744. EN ISO 9614-1 and EN ISO 9614-2 with Grade 2 accuracy may also be used.

B.3.2 When using EN ISO 3744 ten microphones shall be used on a hemispherical surface (see EN ISO 3744:1995, Annex B). Six microphones may be used providing that preliminary investigations have shown that the resulting sound power level value is within ± 1 dB of that determined with the array prescribed.

In this case, the microphone positions shall be the following:

Table B.1 – Microphone positions

X/r	Y/r	Z
0,7	0,7	1,5 m
-0,7	0,7	1,5 m
-0,7	-0,7	1,5 m
0,7	-0,7	1,5 m
-0,27	0,65	0,71r
0,27	-0,65	0,71r

B.3.3 The hemisphere radius shall be at least twice the longest side of the reference parallelepiped and be 4 m or 10 m or 16 m.

B.3.4 The value to be determined is the A-weighted sound power level over a specified work cycle of the machine.

B.3.5 The operator shall be present during the sound power level determination. The standing operator shall be 1,75 m \pm 0,05 m tall including shoes.

B.4 Installation and mounting conditions

B.4.1 The installation and mounting conditions shall be the same for the determination of emission sound pressure levels at the operator position(s) and sound power levels.

B.4.2 Each machine under test shall be standing or supported on a hard reflecting surface, e.g. asphalt concrete and on the standard mounts recommended by the manufacturer, e.g. tyres, tracks, stands or anti-vibration mounts. The operator shall be present at the work-station to feed the machine and to ensure the operation of the machine in the conditions specified in B.5.

B.4.3 Machines powered by an external source, e.g. tractor PTO, shall be powered by a power source sufficient to obtain the operating conditions specified in B.5. The noise level of this power source shall be compatible with the acceptance criteria for the background noise. The evaluation of the background noise shall be carried out when this source is not load operating. The acceptance criteria for the background noise level shall be in accordance with EN ISO 3744 and EN ISO 11201.

B.5 Operating conditions

B.5.1 The operating conditions shall be strictly the same for the determination of both sound power level and emission sound pressure level.

B.5.2 The measurements shall be done over one complete work cycle of the chipping work. The machine shall be operated at or within 10 % of its maximum rated rotational frequency. Provisions to monitor this during measurements shall be made and be recorded in the test report.

B.5.3 The measurements shall be made while chipping a 4 m long (50 ± 10) mm x (50 ± 10) mm air dry, moisture (18 ± 3) %, pine or equivalent wood at maximum infeed speed of the machine. The infeed has to be continuous in order to achieve a measuring period of at least 10 s. The work cycle begins when the wood meets the blades and ends when all the wood is chipped. At the end of the cycle the operator is ready to infeed another wood into the chipper. After feeding the test piece the operator remains standing upright at the position where the feeding was performed. The machine blade setting shall be recorded and reported in the test report. Chips shall be blown 90° clockwise in relation to the feed.

B.6 Measurement uncertainties

Tests shall be repeated until three consecutive A-weighted results give values within 2 dB.

The measuring uncertainty of the determination of A-weighted sound power levels using this document is that specified in EN ISO 3744.

The measurement uncertainty of the determination of A-weighted emission sound pressure levels at work stations using this document is that offered by EN ISO 11201 and EN ISO 11204.

B.7 Information to be recorded and reported

B.7.1 The information to be recorded is defined in the basic documents used for determining the noise emission quantities.

B.7.2 The blade setting, the make and model of the eventual power source (e.g. tractor) shall be reported.

B.7.3 The report shall include the basic documents used and description of the mounting and operating conditions. Workstation locations and emission values at those stations shall also be reported.

B.7.4 The test report shall also confirm that all requirements of this noise test code have been fulfilled or alternatively identify any deviations and list the justification for those necessary deviations.

B.8 Declaration and verification

B.8.1 Noise emission values shall be declared in such fashion that the values can be verified according to the procedures in EN ISO 4871.

NOTE The methodology used for taking uncertainties into account should be based on the use of measured values and measurement uncertainties. The latter are the uncertainty associated to the measurement procedure (which is determined by the grade of accuracy of the measurement method used) and the production uncertainty (variation of noise emission from one machine to another of the same type made by the same manufacturer).

B.8.2 For each A-weighted noise emission quantity declared, the value from which declared values shall be determined is the arithmetic mean of the two highest values obtained from the procedure described in B.6.

B.8.3 The declared values shall be reported as dual-number values. The declared values and their uncertainty shall be determined following the methodology given in EN ISO 4871:1996, Annex A.

B.8.4 The noise declaration shall state that the declared values have been obtained according to this noise test code. If this statement is not true, the noise declaration shall indicate clearly what the deviations are from this noise test code and/or from the basic document(s) used. Reference of the basic noise measurement documents used shall be given in the declaration.

Annex ZA (informative)

Relationship between this European Standard and the Essential Requirements of EU Directive 98/37/EC, amended by Directive 98/79/EC

This European Standard has been prepared under a mandate given to CEN by the European Commission and the European Free Trade Association to provide a means to conforming to Essential Requirements of the New Approach Directive, Machinery Directive 98/37/EC, amended by Directive 98/79/EC.

Once this standard is cited in the Official Journal of the European Communities under that Directive and has been implemented as a national standard in at least one Member State, compliance with the normative clauses of this standard confers, within the limits of the scope of this standard, a presumption of conformity with the relevant Essential Requirements (except Essential Requirement(s) 1.3.4, 1.5.10 and 1.5.11) of that Directive and associated EFTA regulations.

WARNING: Other requirements and other EU Directives may be applicable to the products falling within the scope of this standard.

Bibliography

- [1] EN 12965:2003, *Tractors and machinery for agriculture and forestry – Power take-off (PTO) drive shafts and their guards – Safety*
- [2] EN 13683:2003, *Garden equipment – Integrally powered shredders/chippers – Safety*
- [3] EN ISO 5674:2004, *Tractors and machinery for agriculture and forestry – Guards for power take-off (PTO) drive shafts – Strength and wear tests and acceptance criteria (ISO 5674:2004)*
- [4] EN ISO 11688-2:2000, *Acoustics – Recommended practice for the design of low-noise machinery and equipment – Part 2: Introduction to the physics of low-noise design (ISO/TR 11688-2:1998)*

Licens givet til: Linddana A/S, Ølholm Bygade 70, DK-7160 Tørring

Egne notater/Notes: